

Elastomeric seals — Material requirements for pipe joint seals used in water and drainage applications —

Part 1. Vulcanized rubber

The European Standard EN 681-1:1996, with the incorporation of amendments A1:1998 and A2:2002, has the status of a British Standard

ICS 23.040.80; 83.060

Committees responsible for this British Standard

The preparation of this British Standard was entrusted to Technical Committee PRI/70, Elastomeric seals for joints in pipework and pipelines, upon which the following bodies were represented:

British Gas plc

British Plastics Federation

British Precast Concrete Federation Ltd.

British Rubber Manufacturers' Association Ltd.

Chartered Institution of Water and Environmental Management

Clay Pipe Development Association Limited

Concrete Pipe Association

Ductile Iron Producers' Association

Fibre Cement Manufacturers' Association Limited

Malaysian Rubber Producers Research Association

RAPRA Technology Ltd.

Society of British Water Industries

Water Companies Association

Water Services Association of England and Wales

This British Standard, having been prepared under the direction of the Sector Committee for Materials and Chemicals, was published under the authority of the Standards Committee and comes into effect on 15 November 1996

© BSI 9 December 2002

The following BSI references relate to the work on this standard:

Committee reference PRI/70
Draft for comment 92/38914 DC

Amendments issued since publication

Amd. No.	Date	Comments
10214	December 1998	
13706	26 July 2002	
14178 Corrigendum No. 1	9 December 2002	Indicated by a sideline

ISBN 0 580 22286 1

Contents

	Page
Committees responsible	Inside front cover
National foreword	ii
Foreword	2
Text of EN 681-1	4

National foreword

This British Standard has been prepared by Technical Committee PRI/70 and is the English language version of EN 681-1:1996, *Elastomeric seals — Materials requirements for pipe joint seals used in water and drainage applications — Part 1: Vulcanized rubber*, including amendments A1:1998 and A2:2002 and Corrigendum August 2002, published by the European Committee for Standardization (CEN).

EN 681-1:1996 was produced as a result of international discussions in which the United Kingdom took an active part.

EN 681-1:1996 has been approved by CEN member bodies under the weighted voting procedures introduced in 1988 to coincide with the introduction of “New Approach” Directives from the Commission of the European Community.

To ensure that these products do not have any detrimental effects on the quality of water intended for human consumption, the materials of construction in contact with water will be tested in accordance with the method standards being developed by CEN/TC 64 concerned with effects of materials on water quality.

In the absence of these standards, the respective national standard, BS 6920 applies.

This standard supersedes requirements for vulcanized rubber seals types W, D, H and S, used in water and drainage applications as given in BS 2494 and these types will be withdrawn by amendment. Other Parts of BS EN 681 will be published in the future to supersede requirements for type T and type G seals in BS 2494.

Attention is drawn to paragraph 2 of the European foreword. It was decided by CEN/TC 208 that there would be a one year transition period during which vulcanized rubber seals may be produced to either BS 2494 or BS EN 681-1. Following the changeover period, BS 2494 will be amended to delete requirements for vulcanized rubber seals, i.e. by October 1997.

Cross-references

The British Standards which implement international or European publications referred to in this document may be found in the *BSI Catalogue* under the section entitled “International Standards Correspondence Index”, or by using the “Search” facility of the *BSI Electronic Catalogue* or of British Standard Online.

This publication does not purport to include all the necessary provisions of a contract. Users are responsible for its correct application.

Compliance with a British Standard does not of itself confer immunity from legal obligations.

Summary of pages

This document comprises a front cover, an inside front cover, pages i to ii the EN title page, pages 2 to 19 and a back cover.

The BSI copyright notice displayed in this document indicates when the document was last issued.

Sidelining in this document indicates the most recent changes by amendment.

Descriptors: Rubber products, vulcanized rubber, water pipelines, seal: stoppers, sealing rings, classifications, hardness, physical properties, tests, quality control, designation, marking

English version

Elastomeric seals — Material requirements for pipe joint seals used in water and drainage applications — Part 1: Vulcanized rubber

(includes amendments A1:1998 and A2:2002)

Garnitures d'étanchéité en caoutchouc —
Spécification des matériaux pour garnitures
d'étanchéité pour joints de canalisations utilisées
dans le domaine de l'eau et de l'évacuation —
Partie 1: Caoutchouc vulcanisé
(inclut les amendements A1:1998 et A2:2002)

Elastomer-Dichtungen —
Werkstoff-Anforderungen für
Rohrleitungs-Dichtungen für Anwendungen in der
Wasserversorgung und Entwässerung —
Teil 1: Vulkanisierter Gummi
(enthält Änderungen A1:1998 und A2:2002)

This European Standard was approved by CEN on 1996-04-07; amendment A1 was approved by CEN on 1998-05-28 and amendment A2 was approved by CEN on 2002-02-25. CEN members are bound to comply with the CEN/CENELEC Internal Regulations which stipulate the conditions for giving this European Standard the status of a national standard without any alteration.

Up-to-date lists and bibliographical references concerning such national standards may be obtained on application to the Central Secretariat or to any CEN member.

This European Standard exists in three official versions (English, French, German). A version in any other language made by translation under the responsibility of a CEN member into its own language and notified to the Central Secretariat has the same status as the official versions.

CEN members are the national standards bodies of Austria, Belgium, Denmark, Finland, France, Germany, Greece, Iceland, Ireland, Italy, Luxembourg, Netherlands, Norway, Portugal, Spain, Sweden, Switzerland and United Kingdom.

CEN

European Committee for Standardization
Comité Européen de Normalisation
Europäisches Komitee für Normung

Central Secretariat: rue de Stassart 36, B-1050 Brussels

Foreword

This European Standard has been prepared by Technical Committee CEN/TC 208, Elastomeric seals for joints in pipework and pipelines, the Secretariat of which is held by BSI.

This European Standard shall be given the status of a national standard, either by publication of an identical text or by endorsement, at the latest by October 1996, and conflicting standards shall be withdrawn at the latest by October 1996.

This standard has been prepared under a mandate issued to CEN by the European Commission and the European Free Trade Association and supports Essential Requirements of EU Directives.

For the relationship with the EU Directives, see informative Annex ZA, which is an integral part of this standard.

This Part is based on ISO 4633 and ISO 9631, bringing these two sets of requirements (for cold and hot water respectively) under one specification. The major changes from ISO 4633 and ISO 9631 have been to incorporate requirements for effect on water quality and ozone resistance. The emphasis in respect of low temperature testing has moved away from hardness measurement to compression set, which is more discriminating.

A European Standard is to be prepared for material effects on water quality and when published it is intended that materials comply with the requirements of that standard.

A European Standard is also to be prepared for microbiological deterioration requirements and when published it is intended that materials comply with the requirements of that standard.

Part 2 has been prepared by CEN/TC 208 in response to requests from CEN/TC 155 for a material specification for thermoplastic elastomer seals for use in conjunction with non-pressure thermoplastic pipe systems.

Part 3 has been prepared in response to those sections of the pipeline industry which employ cellular seals of vulcanized rubber.

Part 4 has been prepared in response to those sections of the pipeline industry which employ cast polyurethane seals.

According to the CEN/CENELEC Internal Regulations, the national standards organization of the following countries are bound to implement this European Standard: Austria, Belgium, Denmark, Finland, France, Germany, Greece, Iceland, Ireland, Italy, Luxembourg, Netherlands, Norway, Portugal, Spain, Sweden, Switzerland and the United Kingdom.

Foreword to amendment A1

This amendment EN 681-1:1996/A1:1998 to the EN 681-1:1996 has been prepared by Technical Committee CEN/TC 208, Elastomeric seals for joints in pipework and pipelines, the Secretariat of which is held by BSI.

This amendment to the European Standard EN 681-1:1996 shall be given the status of a national standard, either by publication of an identical text or by endorsement, at the latest by December 1998, and conflicting national standards shall be withdrawn at the latest by December 1998.

According to the CEN/CENELEC Internal Regulations, the national standards organizations of the following countries are bound to implement this European Standard: Austria, Belgium, Czech Republic, Denmark, Finland, France, Germany, Greece, Iceland, Ireland, Italy, Luxembourg, Netherlands, Norway, Portugal, Spain, Sweden, Switzerland and the United Kingdom.

Foreword to amendment A2

This document EN 681-1:1996/A2:2002 has been prepared by Technical Committee CEN/TC 208, Elastomeric seals for joints in pipework and pipelines, the Secretariat of which is held by BSI.

This European Standard shall be given the status of a national standard, either by publication of an identical text or by endorsement, at the latest by September 2002, and conflicting national standards shall be withdrawn at the latest by December 2003.

This document has been prepared under a mandate given to CEN by the European Commission and the European Free Trade Association, and supports essential requirements of EU Directive(s).

For relationship with EU Directive(s), see informative Annex ZA, which is an integral part of this document.

According to the CEN/CENELEC Internal Regulations, the national standards organizations of the following countries are bound to implement this European Standard: Austria, Belgium, Czech Republic, Denmark, Finland, France, Germany, Greece, Iceland, Ireland, Italy, Luxembourg, Netherlands, Norway, Portugal, Spain, Sweden, Switzerland and the United Kingdom.

Contents

	Page
Foreword	2
Introduction	4
1 Scope	4
2 Normative references	4
3 Classification	5
4 Requirements	5
5 Test pieces and temperature	8
6 Factory production control	8
7 Factory product control tests	8
8 Storage	9
9 Designation	9
10 Marking and labelling	9
Annex A (normative) Determination of stress relaxation in tension	13
Annex B (normative) Determination of compression set in hot water at 110 °C	15
Annex C (normative) Determination of splice strength	16
Annex D (informative) Guidance on storage of seals	16
Annex ZA (informative) Clauses of this European Standard addressing the provisions of the EU Construction Products Directive	17

Introduction

The product (in accordance with this standard) which is in permanent or temporary contact with water, intended for human consumption, does not adversely affect the quality of the drinking water and does not contravene the EC Directives and EFTA Regulations on the quality of drinking water.

1 Scope

This standard specifies requirements for materials used in vulcanized rubber seals for:

- 1) cold potable water supply (up to 50 °C);
- 2) hot potable and non-potable water supply (up to 110 °C);
- 3) drainage, sewerage and rainwater systems (continuous flow up to 45 °C and intermittent flow up to 95 °C);

The different designations of seals specified are defined according to their type, application and requirements (see Table 4).

General requirements for finished joint seals are also given; any additional requirements called for by the particular application are specified in the relevant product standards taking into account that the performance of pipe joints is a function of the seal material properties, seal geometry and pipe joint design. This standard should be used where appropriate with product standards which specify performance requirements for joints.

This standard is applicable to joint seals for all pipeline materials, including iron, steel, clay, fibre cement, concrete, reinforced concrete, plastics and glass-reinforced plastics.

It is applicable to elastomeric components of composite or non-composite seals. In the case of composite seals for materials of hardness ranges from 76 IRHD to 95 IRHD the requirements for elongation at break, compression set and stress relaxation apply only when the material is participating in the sealing function, or the long term stability of the seal.

Joint seals made with an enclosed void as part of their design are included in the scope of this European Standard.

2 Normative references

This European Standard incorporates by dated or undated reference, provisions from other publications. These normative references are cited at the appropriate places in the text and the publications are listed hereafter. For dated references subsequent amendments to or revisions of any of these publications apply to this European Standard only when incorporated in it by amendment or revision. For undated references the latest edition of the publication referred to applies.

ISO 37, *Rubber, vulcanized or thermoplastic — Determination of tensile stress-strain properties.*

ISO 48, *Rubber, vulcanized or thermoplastic — Determination of hardness (hardness between 10 IRHD and 100 IRHD).*

ISO 188, *Rubber, vulcanized — Accelerated ageing or heat-resistance tests.*

ISO 471, *Rubber — Times, temperatures, and humidities for conditioning and testing.*

ISO 815, *Rubber, vulcanized or thermoplastic — Determination of compression set at ambient, elevated or low temperatures.*

ISO 816, *Rubber, vulcanized — Determination of tear strength of small test pieces (Delft test pieces).*

ISO 1431-1, *Rubber, vulcanized or thermoplastic — Resistance to ozone cracking — Part 1: Static strain test.*

ISO 1629, *Rubber and latices — Nomenclature.*

ISO 1817, *Rubber, vulcanized — Determination of the effect of liquids.*

ISO 2285, *Rubber, vulcanized or thermoplastic — Determination of tension set at normal and high temperatures.*

ISO 2859-1, *Sampling procedures for inspection by attributes — Part 1: Sampling plans indexed by acceptable quality level (AQL) for lot-by-lot inspection.*

ISO 3302, *Rubber — Dimensional tolerances for use with products.*

ISO 3384, *Rubber, vulcanized or thermoplastic — Determination of stress relaxation in compression at ambient and at elevated temperatures.*

ISO 3387, *Rubbers — Determination of crystallization effects by hardness measurements.*

ISO 3951, *Sampling procedures and charts for inspection by variables for percent nonconforming.*

ISO 4661-1, *Rubber, vulcanized or thermoplastic — Preparation of samples and test pieces — Part 1: Physical tests.*

ISO 9691:1992, *Rubber — Recommendations for the workmanship of pipe joint rings — Description and classification of imperfections.*

EN ISO 9002, *Quality systems — Model for quality assurance in production and installation.*

EN 45011, *General criteria for certification bodies operating product certification.*

EN 45012, *General criteria for certification bodies operating quality system certification.*

3 Classification

Six categories of material for pipe joint seals are specified in Table 2, and 5 categories of materials in Table 3.

A nominal hardness shall be specified within the ranges in Table 1.

Table 1 — Hardness classification

Hardness category	40	50	60	70	80	90
Range of hardness IRHD	36 to 45	46 to 55	56 to 65	66 to 75	76 to 85	86 to 95

4 Requirements

4.1 Materials

4.1.1 General

The materials shall be free of any substances which may have a deleterious effect on the fluid being conveyed, or on the life of the seal, or on the pipe or fitting. Elastomeric components of composite seals not exposed to the contents of the pipeline are not required to meet Clause 4.1.2.

4.1.2 Effect on water quality

For cold and hot potable water applications, the materials shall not impair the quality of the water under the conditions of use. The materials shall comply with the national requirements in the country of use.

4.2 Finished seal requirements

4.2.1 Dimensional tolerances

Tolerances shall be specified from the appropriate classes in ISO 3302.

4.2.2 Imperfections and defects

The seals shall be free of defects or irregularities which could affect their function. Classification of imperfections shall be according to ISO 9691:1992, as follows:

- surface imperfections in zones involved in the sealing function as described in Clause 4.1.1 of ISO 9691:1992 shall be considered as defects;
- surface imperfections in zones not involved in the sealing function as described in Clause 4.1.2.1 b) of ISO 9691:1992 shall not be considered as defects.

NOTE 1 Major surface imperfections in zones not involved in the sealing function as described in Clause 4.1.2.1 a) of ISO 9691:1992 could be considered as defects. This should be agreed between the interested parties; the acceptance criteria depend upon the seals' type or design respectively.

NOTE 2 Internal imperfections as described in Clause 4.2 of ISO 9691:1992 could be considered as defects. The compressive force can be determined according to ISO 7743¹⁾. The acceptable limiting values of the compressive force should be agreed between the interested parties; they depend upon the seals' type or design respectively.

¹⁾ ISO 7743 *Rubber, vulcanized or thermoplastic — Determination of compression stress-strain properties.*

4.2.3 Hardness

When determined by the micro-test method specified in ISO 48, the hardness shall comply with the requirements given in Table 2 and Table 3.

NOTE If the dimensions of a seal are appropriate, the normal test method specified in ISO 48 may be used, provided that the micro-test method is used for reference purposes.

For the same seal, or along the greatest length of an extruded profile cut to make the seal, the difference between the minimum and maximum hardness values shall not be more than 5 IRHD. Each value shall be within the specified tolerances.

4.2.4 Tensile strength and elongation at break

The tensile strength and elongation at break shall be determined by the method specified in ISO 37. Dumb-bell shaped test pieces of types 1, 2, 3 or 4 shall be used. Type 2 is the preferred type. The test report shall state the dumb-bell type whenever type 2 is not used.

The tensile strength and the elongation at break shall comply with the requirements given in Table 2 and Table 3.

4.2.5 Compression set in air

4.2.5.1 General

If the test piece is taken from a seal, then the measurement shall be carried out as far as possible in the direction of compression of the seal in service.

4.2.5.2 Compression set at 23 °C, 70 °C and 125 °C

When determined by the method specified in ISO 815, at 23 °C, 70 °C and 125 °C, using the small type B test piece, the compression set shall comply with the requirements given in Table 2 and Table 3.

Where the cross section is too small to obtain compression buttons from the product, as an alternative to moulding buttons, the tension set of the product may be determined, using the method specified in ISO 2285 with strain 50 % and shall comply with the same test conditions (except strain) and requirements as for compression set.

4.2.5.3 Low temperature compression set at (-10 °C)

When determined by the method specified in ISO 815 at -10 °C using the small type B test piece and the (30 ± 3) min recovery measurement, the compression set of seals used in cold water supply, drainage and sewerage applications shall comply with the requirements given in Table 2.

4.2.6 Accelerated ageing in air

Test pieces prepared for the determination of hardness according to 4.2.3 and for the determination of tensile strength and elongation at break (see 4.2.4) shall be aged in air by the normal oven method specified in ISO 188, for the following temperatures and times:

- joint seals for cold water supply, drainage and sewerage, 7 days at 70 °C;
- joint seals for continuous hot water supply, 7 days at 125 °C.

The changes in hardness, tensile strength and elongation at break shall comply with the requirements given in Table 2 and Table 3.

4.2.7 Stress relaxation in compression

The stress relaxation shall be determined by method A of ISO 3384 using the small cylindrical test piece after applying mechanical and thermal conditioning. Measurements shall be taken after 3 h, 1, 3, 7 days for the 7 day test and after 3 h, 1, 3, 7, 30, 100 days for the 100 days test. The best fit straight line shall be determined by regression analysis using a logarithmic time scale and the correlation coefficients derived from these analyses shall not be lower than 0,93 for the 7 day test and 0,83 for the 100 day test. The 7 day and 100 days requirements in Table 2 and Table 3 are those derived from these straight lines. For continuous measurement using apparatus as described in the first paragraph of 5.2 of ISO 3384:1991, the 7 days and 100 days requirements in Table 2 and Table 3 are those derived from the measurements at 7 days and 100 days.

The stress relaxation in compression shall comply with the requirements given in Table 2 and Table 3 at the following temperatures and times:

Joint seals for cold water supply, drainage, sewerage and rainwater systems	7 days at $23\text{ }^{\circ}\text{C} \pm 2^{\circ}\text{C}$ and 100 days at $23\text{ }^{\circ}\text{C} \pm 2^{\circ}\text{C}$
Joint seals for hot water supply	7 days at $23\text{ }^{\circ}\text{C} \pm 2^{\circ}\text{C}$ and 7 days at $125\text{ }^{\circ}\text{C} \pm 2^{\circ}\text{C}$

The test temperature shall be maintained within the specified tolerance during the whole period of the test and verified by suitable recording equipment on a continuous basis.

The 100 days test shall be considered as a type approval test.

If the test piece is taken from a seal, then the measurement shall be carried out as far as possible in the direction of compression of the seal in service.

Where the cross section is too small to obtain compression buttons from the product, as an alternative to moulding test pieces the stress relaxation in tension of the product may be determined, using the method specified in Annex A with the same requirements as for stress relaxation in compression.

For seals manufactured from isoprene–isobutylene copolymers see 4.2.11 for an alternative test.

4.2.8 Volume change in water

When determined by the method specified in ISO 1817 after 7 days immersion in distilled or deionized water at the temperatures specified below:

Joint seals for cold water supply, drainage, sewerage and rainwater systems	$70\text{ }^{\circ}\text{C}$
Joint seals for hot water supply	$95\text{ }^{\circ}\text{C}$

The change in volume shall comply with the requirements given in Table 2 and Table 3. For seals manufactured from isoprene–isobutylene copolymers see 4.2.1.1 for an alternative test.

4.2.9 Ozone resistance

When determined by the method specified in ISO 1431-1 under the conditions set out below:

Ozone concentration	(50 ± 5) p.p.h.m
Temperature	(40 ± 2) $^{\circ}\text{C}$
Pretension time	(72_{-2}^0) h
Exposure time	(48_{-2}^0) h
Elongation	36 to 75 IRHD (20 ± 2) % 76 to 85 IRHD (15 ± 2) % 86 to 95 IRHD (10 ± 1) %
Relative humidity	(55 ± 10) %

the ozone resistance of vulcanized rubber sealing elements which are attached to the pipe or fittings shall comply with the requirements given in Table 2 and Table 3.

Rubber sealing elements which are protected and packaged separately up to the time of installation shall meet the same requirement but using an ozone concentration of (25 ± 5) p.p.h.m.

4.2.10 Tear strength for joint seals for hot water supply

When determined by the method specified in ISO 816 the tear strength shall comply with the requirements given in Table 3.

For seals manufactured from isoprene–isobutylene copolymers see 4.2.11 for an alternative test.

4.2.11 Compression set in water for joint seals for hot water supply

The materials shall comply with the requirements given in Table 3.

For seals manufactured from isoprene–isobutylene copolymers only, as an alternative to requirements in 4.2.7, 4.2.8 and 4.2.10 the compression set in water may be determined using the method specified in Annex B.

4.2.12 *Splices of prevulcanized profile ends*

4.2.12.1 Spliced joints shall be vulcanized.

4.2.12.2 *Strength of spliced joints*

When tested using the method specified in Annex C there shall be no visible separation in the cross sectional area of the splice, when viewed without magnification.

4.3 **Optional requirements for joint seals for cold water supply, drainage and sewerage**

4.3.1 *General*

If seals meet the optional additional requirements as specified in 4.3.2 and 4.3.3 they shall be appropriately marked (see 10).

4.3.2 *Low temperature performance at -25 °C*

When determined by the method specified in ISO 815 at -25 °C, using the small type B test piece and the (30 ± 3) min recovery measurement, the compression set of the seals shall comply with the requirements given in Table 2.

When determined by the method specified in ISO 3387 the hardness change at -25 °C shall comply with the requirements given in Table 2.

4.3.3 *Volume change in oil*

The resistance to oil shall be determined according to ISO 1817. The volume change of test pieces shall be determined after 72 h immersion in standard oils No 1 and No 3 at a temperature of 70 °C.

The volume change in oil shall comply with the requirements in Table 2.

NOTE If No. 3 oil is no longer available it is recommended that IRM903 is used.

5 **Test pieces and temperature**

5.1 **Preparation of test pieces**

Unless otherwise specified test pieces shall be cut from the finished product by the method specified in ISO 4661-1. If satisfactory test pieces cannot be prepared in accordance with the instructions given for the appropriate test method they shall be taken from test slabs or sheets, of suitable dimensions, made from the same batch of the elastomer mix used to make the seals and moulded under conditions which are comparable with those used in production.

For tests in which different sizes of test pieces are permissible, the same size of test piece shall be used for each batch and for any comparative purposes.

5.2 **Test temperature**

Unless otherwise specified, tests shall be carried out at (23 ± 2) °C, in accordance with ISO 471.

NOTE Two standard laboratory temperatures are given in this standard.

6 **Factory production control**

The manufacturer shall establish and maintain an effective documented factory production control system, so as to achieve conformance with product standards.

Internal quality control shall comprise continuous inspection carried out by the manufacturer as part of an approved third party assessment to ensure compliance with the requirements of this product standard under a quality system complying with EN ISO 9000 series or equivalent.

7 **Factory product control tests**

7.1 **Sampling**

The product control tests shall be carried out on lots of finished components using sampling procedures in accordance with either:

- a) ISO 2859-1 with a specified inspection level of S2 and an AQL of 2.5 % for attributes; or
- b) ISO 3951 with a specified inspection level of S3 and an AQL of 2.5 % for variables.

These requirements do not preclude the use by the manufacturer of more stringent combinations of inspection levels and AQL values from ISO 2859-1 or ISO 3951.

7.2 Routine tests

Tests in accordance with 4.2.1 and 4.2.2 shall be carried out. The following tests shall be carried out according to the methods listed in Table 2 and Table 3 using test pieces in accordance with 5.1.

- a) Hardness.
- b) Tensile strength.
- c) Elongation at break.
- d) Compression set for 24 h at 70 °C or at 125 °C (where appropriate).
- e) Splice strength where appropriate.

7.3 Type tests

All tests except those having a duration in excess of 28 days shall be carried out at least annually and whenever the manufacturing technique is changed significantly. Those tests having a duration in excess of 28 days shall be repeated at five year intervals. All tests, without exception, shall also be carried out initially and whenever the elastomer formulation is changed significantly.

8 Storage

See Annex D.

9 Designation

Elastomeric seals for pipelines are designated according to their intended application as described in Table 4. The following information shall be used for a full designation of the seals:

- a) Description, e.g. "O" ring.
- b) European Standard, No. i.e. EN 681-1.
- c) Nominal size, e.g. DN 150.
- d) Type of application, e.g. WA (see Table 4).
- e) Rubber type, e.g. SBR (see ISO 1629).
- f) Joint name, e.g. "Tradename".

Example

"O" ring/EN 681-1/DN 150/WA/SBR/Tradename.

10 Marking and labelling

Each seal or parcel of seals where the marking is not practicable, shall be marked clearly and durably, as listed below, such that the sealing capability is not impaired:

- a) Nominal size.
- b) Manufacturer's identification.
- c) The number of this standard with the type of application and hardness category as a suffix, e.g. EN 681-1/ WB/50.
- d) Third party certification mark.
- e) The quarter and year of manufacture.
- f) Low temperature resistance (L) if appropriate, e.g. WAL.
- g) Oil resistant (O) if appropriate, e.g. WCO.
- h) The abbreviation for the rubber, e.g. SBR.

Table 2 — Physical property requirements for materials used in cold water supply, drainage, sewerage and rainwater systems

Types WA, WC and WG				Requirements for hardness categories					
Property	Unit	Test method	Clause	40	50	60	70	80	90
Permissible tolerance on nominal hardness	IRHD	ISO 48	4.2.3	±5	±5	±5	±5	±5	±5
Tensile strength, min.	MPa	ISO 37	4.2.4	9	9	9	9	9	9
Elongation at break, min.	%	ISO 37	4.2.4	400	375	300	200	125	100
Compression set, max.									
72 h at 23 °C	%	ISO 815	4.2.5.2	12	12	12	15	15	15
24 h at 70 °C	%	ISO 815	4.2.5.2	20	20	20	20	20	20
72 h at -10 °C	%	ISO 815	4.2.5.3	40	40	50	50	60	60
Ageing, 7 days at 70 °C		ISO 188	4.2.6						
Hardness change, max.	IRHD	ISO 48		+8/-5	+8/-5	+8/-5	+8/-5	+8/-5	+5/-5
Tensile strength change, max.	%	ISO 37		-20	-20	-20	-20	-20	-20
Elongation change, max.	%	ISO 37		+10/-30	+10/-30	+10/-30	+10/-30	+10/-40	+10/-40
Stress relaxation, max.		ISO 3384	4.2.7						
7 days at 23 °C	%			13	14	15	16	17	18
100 days at 23 °C	%			19	20	22	23	25	26
Volume change in water, 7 days at 70 °C, max.	%	ISO 1817	4.2.8	+8/-1	+8/-1	+8/-1	+8/-1	+8/-1	+8/-1
Ozone resistance	—	ISO 1431-1	4.2.9	No cracking when viewed without magnification					
Optional requirements									
Compression set, max. 72 h at -25 °C	%	ISO 815	4.3.2	60	60	60	70	70	70
Hardness change, max. 168 h at -25 °C	IRHD	ISO 3387	4.3.2	+18	+18	+18	—	—	—
Volume change in oil, max. 72 h at 70 °C		ISO 1817	4.3.3						
Oil No. 1	%			±10	±10	±10	±10	±10	±10
Oil No. 3	%			+50/-5	+50/-5	+50/-5	+50/-5	+50/-5	+50/-5

Table 3 — Physical property requirements for materials used in continuous hot water supply up to 110 °C

Types WB, WD, WE, WF				Requirements for hardness categories				
Property	Unit	Test method	Clause	50	60	70	80	90
Permissible tolerance on nominal hardness	IRHD	ISO 48	4.2.3	±5	±5	±5	±5	±5
Tensile strength, min.	MPa	ISO 37	4.2.4	9	9	9	9	9
Elongation at break, min.	%	ISO 37	4.2.4	250	200	150	100	100
Compression set, max.								
72 h at 23 °C	%	ISO 815	4.2.5.2	15	15	15	15	15
24 h at 125 °C	%	ISO 815	4.2.5.2	20	20	20	20	20
Ageing, 7 days at 125 °C		ISO 188	4.2.6					
Hardness change, max.	IRHD	ISO 48		+8/-5	+8/-5	+8/-5	+8/-5	+5/-5
Tensile strength change, max.	%	ISO 37		-20	-20	-20	-20	-20
Elongation change, max.	%	ISO 37		+10/-30	+10/-30	+10/-30	+10/-40	+10/-40
Stress relaxation, max.		ISO 3384	4.2.7					
7 days at 23 °C	%			15	15	15	18	18
7 days at 125 °C ¹⁾	%			30	30	30	30	30
Volume change in water, max. ¹⁾	%	ISO 1817	4.2.8	+8/-1	+8/-1	+8/-1	+8/-1	+8/-1
7 days at 95 °C								
Ozone resistance	—	ISO 1431-1	4.2.9	No cracking when viewed without magnification				
Tear strength, min. ¹⁾	N	ISO 816	4.2.10	20	20	20	20	20
Compression set in water, max. ¹⁾²⁾		Annex B						
70 days at 110 °C	%		4.2.11	30	30	30	30	30

¹⁾ See Clause 4.2.11.

²⁾ This requirement only applies to isoprene-isobutylene copolymers.

Table 4 — Designation of elastomeric joint seals by type, application and requirements

Type	Application	Requirements	Clause nos.
WA	Cold potable water supply (up to 50 °C)	Table 2 Effect on water quality	4.1.2
WB	Hot potable water (continuous supply up to 110 °C)	Table 3 Effect on water quality	4.1.2
WC	Cold non-potable water supply, drainage, sewerage and rainwater pipes (continuous flow up to 45 °C and intermittent flow up to 95 °C)	Table 2	4.1.3
WD	Hot non-potable water (continuous supply up to 110 °C)	Table 3	4.1.3
WE	Hot potable water (continuous supply up to 110 °C) seals manufactured from isoprene–isobutylene copolymer	Table 3 Effect on water quality Compression set in hot water	4.1.2 4.2.11
WF	Hot non-potable water (continuous supply up to 110 °C) seals manufactured from isoprene–isobutylene copolymer	Table 3 Compression set in hot water	4.2.11
WG	Cold non-potable water supply, drainage, sewerage and rainwater pipes (continuous flow up to 45 °C and intermittent flow up to 95 °C) with oil resistance	Table 2 Oil resistance	4.3.2

Annex A (normative)

Determination of stress relaxation in tension

A.1 Principle

Measurements of force, taken over a period of time, on a test piece at a fixed extended length.

A.2 Apparatus

A.2.1 *Stress apparatus* consisting of two grips holding the test piece, without slipping, at a fixed extended length (see example in Figure A.1).

Grips arranged such that the force in the test piece can be measured e.g. by fitting the stress apparatus to a tensile testing machine.

A.2.2 *Force measuring system*, accurate and stable to within 2 % of the force reading.

A.3 Test pieces

Parallel sided strips prepared from the finished seal with dimensions as follows:

Thickness: 1 mm to 2 mm

Width: 4 mm to 10 mm

Length: (80 ± 1) mm plus two times the gripping length

Three test pieces shall be used for each test.

A.4 Test conditions

Test temperature as given in 4.2.7.

The test temperature shall be maintained within the specified tolerance during the whole period of the test and verified by suitable recording equipment on a continuous basis.

A.5 Procedure

Mount the test piece in the grips in an unstrained condition. In less than 1 min stretch the test piece to an elongation between 45 % and 55 %. Maintain this elongation throughout the test.

Measure the initial force, F_0 , (30 ± 0.5) min after stretching the test piece.

Take further force measurements, F_e , as specified in 4.2.7.

NOTE If a stress apparatus according to Figure A.1 is used, fit the device to a tensile testing machine. Take the force readings either by turning the knurled screws down or by using an additional strain to make the upper grip free from the supporting screws both by not more than 0.2 mm. After measuring the tension force, relieve to the initial strain, remove the stress apparatus from the tensile machine and store it aside.

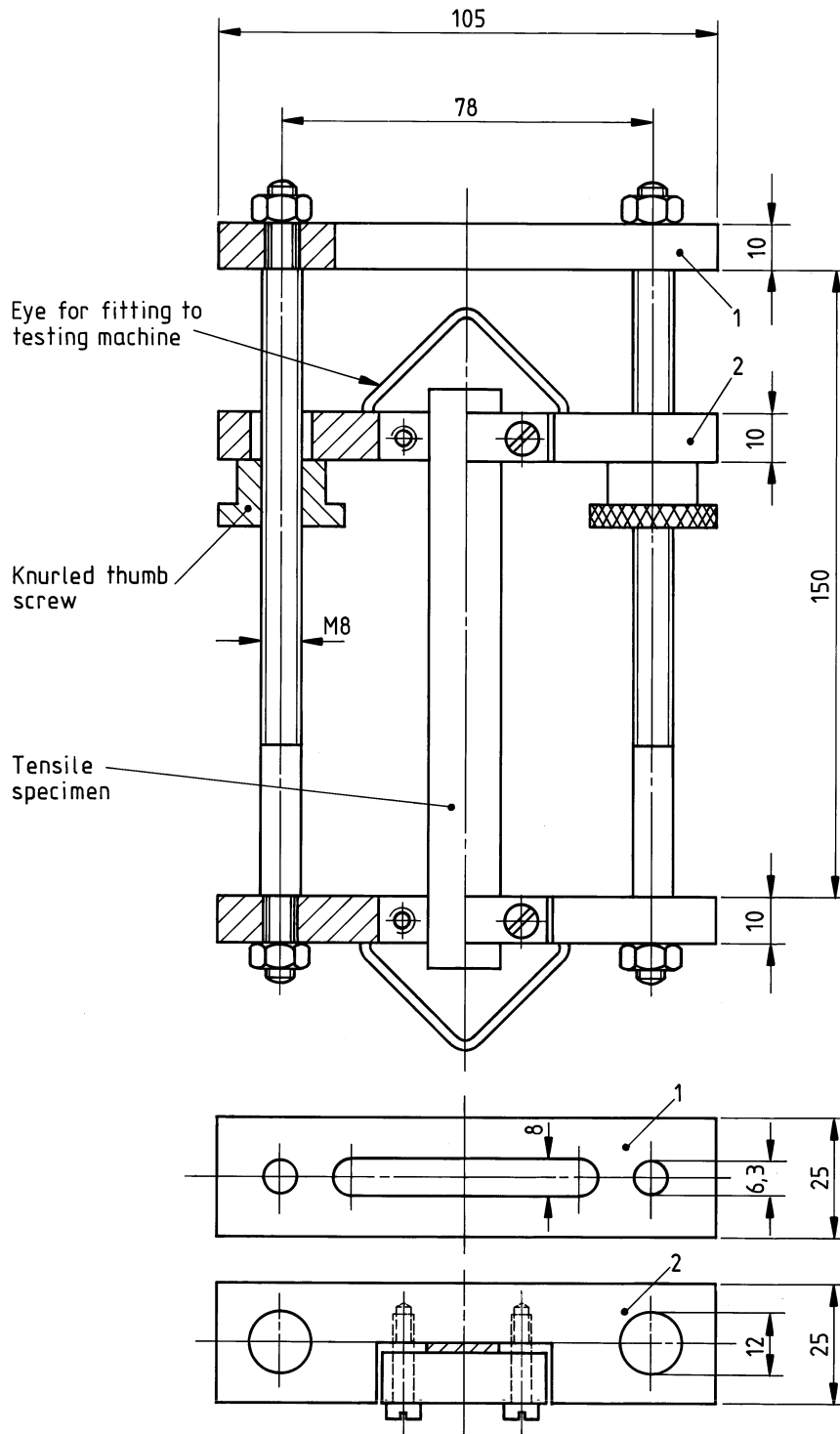

**Figure A.1 — Apparatus for testing the stress relaxation in tension
[the dimensions (in mm) are given for guidance only]**

Annex B (normative)

Determination of compression set in hot water at 110 °C

B.1 Principle

Measurement of compression set of seal rings after immersion in hot water.

B.2 Apparatus

B.2.1 Compression jig (see Figure B.1).

B.2.2 Autoclave

B.3 Test pieces

Consist of "O" rings taken from production. At least 3 test pieces shall be tested.

B.4 Procedure

Place the "O" rings and compress in the jig. The "O" ring deformation between the steel plates of the compression jig shall be 25 %. Immerse the jig and "O" rings for 70 days in distilled or deionized water at a temperature of $(110 \pm 1,5) \text{ }^\circ\text{C}$ (autoclave).

Immediately after taking the compression jig out of the autoclave, discharge the "O" rings and cool for 30 min in ambient conditions.

Carry out the measurement of compression set in accordance with the method specified in ISO 815.

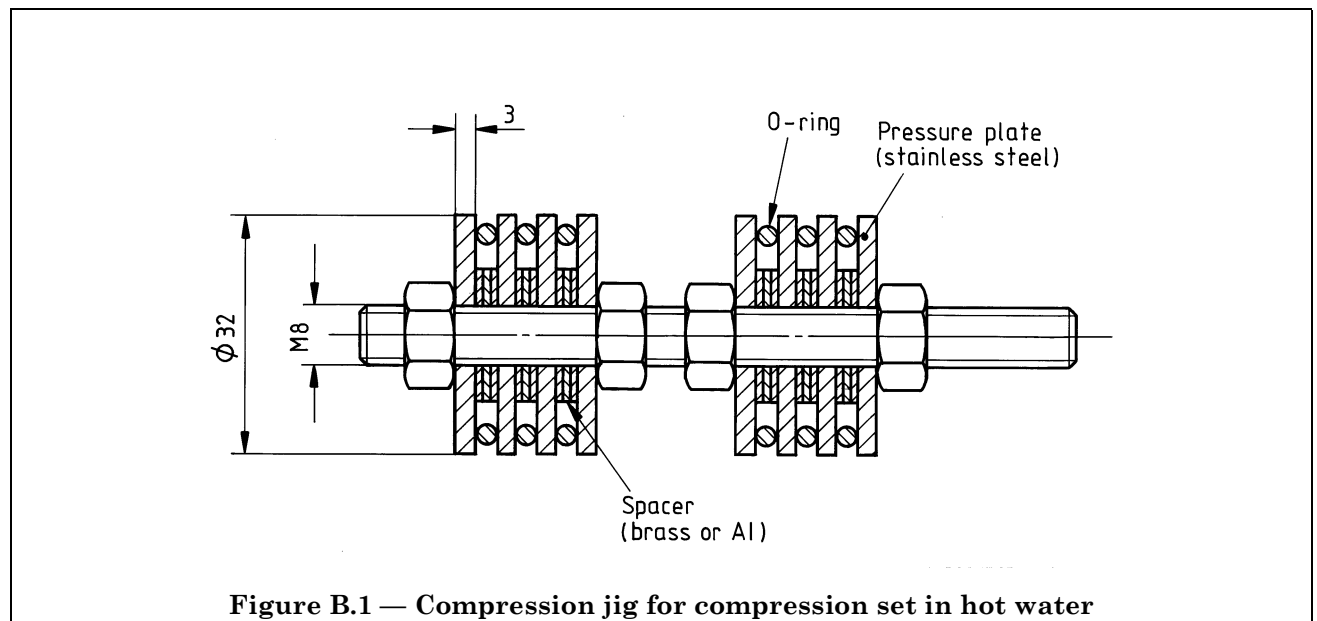

Annex C (normative)

Determination of splice strength

C.1 Principle

Seals spliced from prevulcanized rubber are elongated and examined.

C.2 Test pieces

Perform the test either on the seal itself or on a test piece 200 mm long with the splice at the mid-point i.e. such that there is a length of 100 mm on each side of the splice.

C.3 Procedure

Make two reference marks, equidistant from the splice and 50 mm apart, on the test piece, extend the seal or test piece at a rate of $(8,3 \pm 0,8)$ mm/s until the elongation between the reference marks is as specified in Table C.1. Maintain this extension for 1 min and examine the seal or test piece under tension.

Table C.1 — Required elongation between reference marks for splice strength

Hardness category	Elongation
up to 70	100 %
80	75 %
90	50 %

Annex D (informative)

Guidance on storage of seals

At all stages between manufacture and use the seals should be stored in accordance with the recommendations given in ISO 2230²⁾.

The following points should be noted.

- a) The storage temperature should be below 25 °C and preferably below 15 °C.
- b) The seals should be protected from light, in particular strong sunlight and artificial light with a high ultraviolet content.
- c) The seals should not be stored in a room with any equipment capable of generating ozone, e.g. mercury vapour lamps, high voltage electrical equipment, which may give rise to electrical sparks or silent electrical discharges.
- d) The seals should be stored in a relaxed condition free from tension, compression or other deformation. For instance, they should not be suspended from any part of the circumference.
- e) The seals should be maintained in a clean condition.

²⁾ ISO 2230, *Vulcanized rubber — Guide to storage*.

Annex ZA (informative)

Clauses of this European Standard addressing the provisions of the EU Construction Products Directive

ZA.1 Scope and clauses of European Standard addressing the essential characteristics of the EU Construction Products Directive

With reference to clause 1, this Annex ZA has the same scope as clause 1, excluding uses in contact with water intended for human consumption.

This European Standard has been prepared under a Mandate given to CEN by the European Commission and the European Free Trade Association.

The clauses of this European Standard shown in Table ZA.1 below meet the requirements of the Mandate given under the EU Construction Products Directive (89/106). Compliance with these clauses confers a presumption of fitness of elastomeric seals — vulcanized rubber covered by this European Standard for their intended use.

WARNING Other requirements and other EU Directives, not affecting the fitness for intended use may be applicable to a construction product falling within the scope of this standard.

NOTE 1 In addition to any specific clauses relating to dangerous substances contained in this standard, there may be other requirements applicable to the products falling within its scope (e.g. transposed European legislation and national laws, regulations and administrative provisions). In order to meet the **provisions** of the EU Construction Products Directive, these requirements **need** also to be complied with, when and where they apply.

NOTE 2 An informative database of European and national provisions on dangerous substances is available at the Construction web site on EUROPA (CREATE, accessed through <http://europa.eu.int>).

Construction product:	Elastomeric seals — Vulcanized rubber
Intended uses:	For pipe joints used in water and drainage applications, excluding uses in contact with water intended for human consumption

Table ZA.1 — Relevant clauses

Requirement/characteristic from the mandate	Requirement clauses in this standard	Mandated levels and/or classes	Notes
Dimensional tolerance	4.2.1	—	See ISO 3302
Tightness: gas and liquid	4.2.3, 4.2.4, 4.2.5, 4.2.8	Threshold values — see Table 2 and Table 3	See ISO 48, ISO 37, ISO 815, and ISO 1817
Release of dangerous substances	None	—	
Durability	4.2.6, 4.2.7, 4.2.9	Threshold values — see Table 2 and Table 3	See ISO 188, ISO 1431-1, and ISO 3384

The requirement on a certain characteristic is not applicable in those Member States (MSs) where there are no regulatory requirements on that characteristic for the intended use of the product. In this case, manufacturers placing their products on the market of these MSs are not obliged to determine nor declare the performance of their products with regard to this characteristic and the option “No performance determined” (NPD) in the information accompanying the CE marking (see Clause **ZA.3**) may be used. The NPD option may not be used, however, where the characteristic is subject to a threshold level.

ZA.2 System of attestation of conformity

The system of attestation of conformity for elastomeric seals — vulcanized rubber indicated in Table ZA.1, in accordance with the decision of the Commission “1999/472/EC of 1 July 1999” as given in Annex III of the mandate M 131, *Pipes, tanks and ancillaries not in contact with water intended for human consumption*, is shown in Table ZA.2 for the indicated intended use(s).

Table ZA.2 — Attestation of conformity system

Product	Intended use	Level or class	Attestation of conformity system(s)
Joint sealings	In installations for the transport/disposal/storage of water not intended for human consumption	—	4
System 4: See CPD Annex III.2.(ii), third possibility, initial type testing by the manufacturer and manufacturer's factory production control.			

The attestation of conformity of the products in Table ZA.1 shall be based on the evaluation of conformity procedure resulting from the clauses of this EN indicated in Table ZA.3.

Table ZA.3 — Assignment of evaluation of conformity tasks

Tasks	Content of the task	Clauses to apply
Tasks for the manufacturer	(1) Factory production control (F.P.C.)	Parameters related to all characteristics of Table ZA.1 6 and 7 (excluding 7.3)
	(2) Initial type testing	All characteristics of Table ZA.1 7.3

For each product, the manufacturer shall draw up a declaration of conformity (EC Declaration of conformity) including the following information:

- Name and address of the manufacturer, or his authorized representative established in the EEA.
- Description of the product (type, identification, use).
- Provisions to which the product conforms (e.g. Annex ZA of this EN).
- Particular conditions applicable to the use of the product.
- Name of, and position held by, the person empowered to sign the declaration on behalf of the manufacturer or of his authorized representative.

This declaration of conformity entitles the manufacturer to affix the CE marking, as described in **ZA.3**, and shall be presented in the official language or languages of the Member State of the EU in which the product is to be used.

ZA.3 CE Marking

The manufacturer or his authorized representative established within the EU or EFTA is responsible for the affixing of the CE Marking.

The CE conformity symbol to affix shall be in accordance with Directive 93/68/EC and shall be shown on the packaging and/or on the accompanying commercial documents, together with the following information:

- Name or identifying mark of the producer.
- The last two digits in which the marking is affixed.
- Registered address of the producer.
- Product type, e.g. seal material and hardness category.
- Reference to this European Standard.
- Intended use.

In addition to specific information relating to dangerous substances, if any, the product should also be accompanied, when and where required and in the appropriate form, by documentation listing any other legislation on dangerous substances for which compliance is claimed, together with any information required by that legislation.

NOTE European legislation without national derogations need not be mentioned.

Figure ZA.1 gives an example of the information to be given on the packaging and/or on the commercial documents.

CE 00	CE conformity marking consisting of the CE symbol given in directive 93/68/EC Last two digits of year of affixing of CE marking
Any Co Ltd, P.O. Box 21, B — 1050	Name of identifying mark and registered address of the producer
SBR — 60 EN 681-1 GB	Seal material — Category Number of European Standard Intended us

Figure ZA.1 — Example CE marking information

BSI — British Standards Institution

BSI is the independent national body responsible for preparing British Standards. It presents the UK view on standards in Europe and at the international level. It is incorporated by Royal Charter.

Revisions

British Standards are updated by amendment or revision. Users of British Standards should make sure that they possess the latest amendments or editions.

It is the constant aim of BSI to improve the quality of our products and services. We would be grateful if anyone finding an inaccuracy or ambiguity while using this British Standard would inform the Secretary of the technical committee responsible, the identity of which can be found on the inside front cover. Tel: +44 (0)20 8996 9000. Fax: +44 (0)20 8996 7400.

BSI offers members an individual updating service called PLUS which ensures that subscribers automatically receive the latest editions of standards.

Buying standards

Orders for all BSI, international and foreign standards publications should be addressed to Customer Services. Tel: +44 (0)20 8996 9001. Fax: +44 (0)20 8996 7001. Email: orders@bsi-global.com. Standards are also available from the BSI website at <http://www.bsi-global.com>.

In response to orders for international standards, it is BSI policy to supply the BSI implementation of those that have been published as British Standards, unless otherwise requested.

Information on standards

BSI provides a wide range of information on national, European and international standards through its Library and its Technical Help to Exporters Service. Various BSI electronic information services are also available which give details on all its products and services. Contact the Information Centre. Tel: +44 (0)20 8996 7111. Fax: +44 (0)20 8996 7048. Email: info@bsi-global.com.

Subscribing members of BSI are kept up to date with standards developments and receive substantial discounts on the purchase price of standards. For details of these and other benefits contact Membership Administration. Tel: +44 (0)20 8996 7002. Fax: +44 (0)20 8996 7001. Email: membership@bsi-global.com.

Information regarding online access to British Standards via British Standards Online can be found at <http://www.bsi-global.com/bsonline>.

Further information about BSI is available on the BSI website at <http://www.bsi-global.com>.

Copyright

Copyright subsists in all BSI publications. BSI also holds the copyright, in the UK, of the publications of the international standardization bodies. Except as permitted under the Copyright, Designs and Patents Act 1988 no extract may be reproduced, stored in a retrieval system or transmitted in any form or by any means – electronic, photocopying, recording or otherwise – without prior written permission from BSI.

This does not preclude the free use, in the course of implementing the standard, of necessary details such as symbols, and size, type or grade designations. If these details are to be used for any other purpose than implementation then the prior written permission of BSI must be obtained.

Details and advice can be obtained from the Copyright & Licensing Manager. Tel: +44 (0)20 8996 7070. Fax: +44 (0)20 8996 7553. Email: copyright@bsi-global.com.

BSI
389 Chiswick High Road
London
W4 4AL